

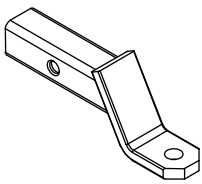

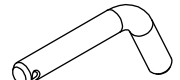



Part list:

Pos. 1	Main bar 	Pos. 3	Safety bolt 	Pos. 6	Spring washer ø22,5mm 
PCS.: 1		PCS.: 1		PCS.: 1	
Pos. 2	Część kulista 	Pos. 4	Safety pin 	Pos. 7	Nut 8 B M22 
PCS.: 1		PCS.: 1		PCS.: 1	
		Pos. 5	Plain washer ø23mm 		
		PCS.: 1			



PPUH AUTO-HAK Sp.J.

Produkcja Zaczepów Kulowych
Henryk & Zbigniew Nejman
76-200 SŁUPSK ul. Słoneczna 16K
tel/fax (059) 8-414-414; 8-414-413
E-mail: office@autohak.com.pl
www.autohak.com.pl

Universal towing hitch

Class: **A50-X** Cat. no. **AH-1**
**Designed for cars factory prepared
for installation of this type towbar.**

Technical data:
D-value: 14,0 kN
maximum trailer weight: **3500 kg**
maximum vertical cup mass: **100 kg**

Approval number according to Directive 94/20/EC: e20*94/20*0517*00

Foreword

This towing hitch is designed according to rules of safety traffic regulations. The towing hitch is a safety component and can be install only by qualified personnel. Any alteration or conversion of the towing hitch is prohibited and would lead to cancellation of design certification. Remove insulating compound and underseal from vehicle (if present) in the areas of the matting surfaces of the towing hitch. The vehicle manufacturer's specifications regarding trailer load and max. vertical cup mass are decisive for driving whereat values for the towing hitch cannot be exceeded.

D-value formula:

$$\frac{\text{Max trailer weight [kg]} \times \text{Max vehicle weight [kg]}}{\text{Max trailer weight [kg]} + \text{Max vehicle weight [kg]}} \times \frac{9,81}{1000} = D \text{ [kN]}$$

FITTING INSTRUCTION

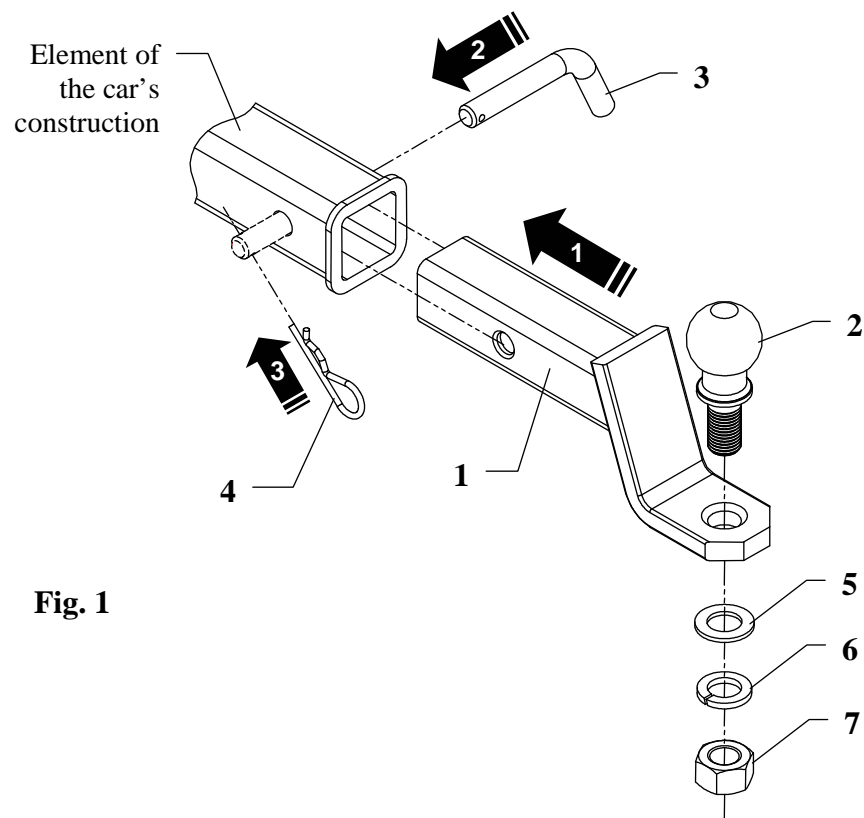

Fig. 1

Towing hitch **AH-1** is designed to assembly in cars factory prepared for installation of this type towbar. Universal towbar is prepared to tow trailers max total weight **3500 kg** and max vertical mass **100 kg**.

From manufacturer

Thank you for buying our product. Their reliability has been confirmed in many tests. Reliability of towing hitch depends also on correct assembly and right operation. For this reasons we kindly ask to read carefully this instruction and apply to hints.

The towing hitch should be installed in points described by a car producer.

The instruction of the assembly

1. In rear part of a car find factory prepared element of construction and slip in main bar of the towbar (pos. 1). Hole in main bar should agree with original prepared hole in car element.
2. Slip in bolt (pos. 3) and shift safety pin (pos. 4). Correctly placed safety pin is shown on figure 2.
3. Fix tow-ball (pos. 2) as shown on figure 1 using supplied washers (pos. 5 and 6) and nut M22 (pos. 7).
Attention! Before towing screw tight all elements!
4. Complete paint layer damaged during installation.

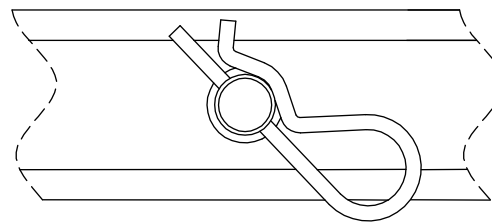

Fig. 2 Correctly placed safety pin.

NOTE

After installation of the towing hitch you should get adequate note in registration book (at authorised service station).The car should be equipped with:

- Indicators
- Tow mirrors

Check all bolts and nuts after **1000 km** of exploitation. The ball of the towing hitch must be always kept clear and conserve with a grease.